

InterSense Wireless InertiaCube3



Precision Orientation Reference System

- Inertial-based tracking from integration of nine sensing elements
- Sourceless tracking with full 360° range
- 180 Hz update rate with adjustable motion prediction
- Adjustable output filters and rotational sensitivity
- MagCal software for in-situ heading calibration
- Supports up to 4 wireless sensors per USB receiver
- Windows software provides simple configuration, network interface and joystick emulation
- SDK for OEM applications on Windows and Linux platforms

The InertiaCube3 is the world's smallest inertial orientation reference system. Providing full 360° sourceless tracking in all axes, the InertiaCube3 integrates nine discrete, miniature sensing elements with advanced Kalman filtering algorithms. Its simple serial or USB interface with support software provides a rapid development cycle for OEM applications.

The low power consumption and wide temperature range of the InertiaCube3 make it ideal for head or body tracking in mobile simulation, training and situational awareness applications. The wireless InertiaCube3 supports a standard I²C interface bus allowing custom button, indicator or analog interfaces through the wireless channel for OEM applications. Standard heading calibration software compensates for static magnetic field distortions when the InertiaCube3 is deployed in adverse environments.

Wireless InertiaCube3 Specifications

Degrees of Freedom	3 (Yaw, Pitch and Roll)
Angular Range	Full 360° - All Axes
Maximum Angular Rate*	1200° per second
Minimum Angular Rate*	0° per second
RMS Accuracy*	1° in yaw, 0.25° in pitch & roll at 25°C
RMS Angular Resolution*	0.03°
Update Rate	180 Hz (up to two sensors per receiver) 120 Hz (three to four sensors per receiver)
Minimum Latency	< 6 ms (host OS dependent)
Prediction	up to 50 milliseconds
Wireless Receiver Interface	USB (supports four wireless sensors) RS-232 Serial (supports one wireless sensor at 115.2 kbaud and up to four at 230.4 kbaud)
Size (without mounting plate)	1.232 in x 1.700 in x 0.581 in (31.3 mm x 43.2 mm x 14.8 mm)
Weight	0.7 ounces (20.0 grams)
InertiaCube3 Battery Power Operation	9 VDC Battery for 8 hours continuous
Operating Temperature Range	0° to 70° C
O/S Compatibility	.dll for Windows Vista/XP/2000 .so for Linux
Software Support	SDK with full InterSense API Ethernet via Windows Control Software Heading Calibration Software Windows Wireless Configuration Software
Receiver Power Source	USB (direct from host USB port) Serial (6 VDC External Supply)
Wireless Receiver Size	2.36 in x 1.38 in x 0.79 in (60 mm x 35 mm x 20 mm)
Wireless Receiver Cable Length	6.4 feet (2 meters)
Wireless Sensor Range	up to 100 feet (30 meters)

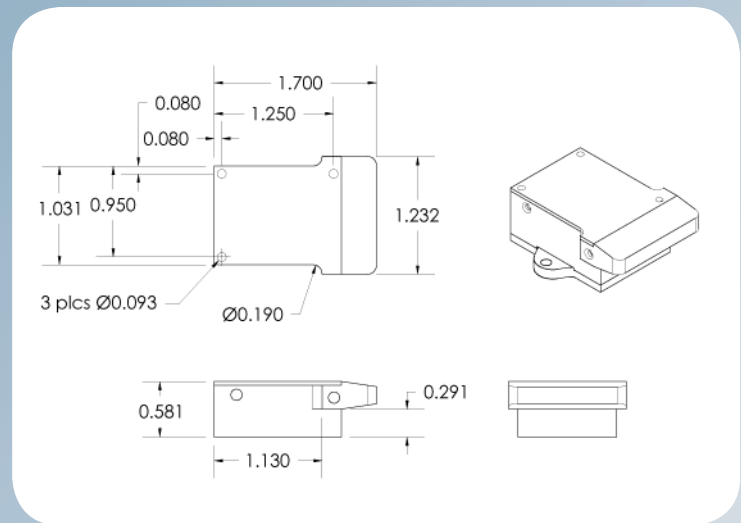

**Wireless InertiaCube3
(dimensions in inches)**

*Measurements with perceptual enhancement algorithm turned off (= 0)

InterSense Inc.

4 Federal Street • Billerica, MA 01821

+1 781 541 6330 • FAX +1 781 541 6329 • Info@intersense.com



INTERSENSE
www.intersense.com